



### BOSTON – Flat top Exterior Bollard Range

- ☺ **Graffiti-Resistant diffuser**
- ☺ **Steel body**
- ☺ **Flange plate or root mounting**
- ☺ **Various colour finish options**
- ☺ **Excellent Photometric Performance**

#### Description

The BOSTON range of Vandal Resistant Bollards are suitable for many exterior lighting applications. The tubular body is manufactured from 3mm thick steel which is given a special phosphate coating under a resilient textured black EPC paint finish as standard. Versions are available in either root or flange mounting.





The thick acrylic lens covers a white gloss finish louvre stack and is held in place by a cast alloy top and collar. The top is available in either domed or flat style and is also given the textured black EPC finish. The geartray is manufactured from galvanised steel and is removable for ease of maintenance. Versions are available using high efficacy discharge lamps such as high pressure sodium and mercury and also the latest compact fluorescent triple lamps with high frequency electronic gear. The advantage of the latter is that light output is virtually instantaneous.

All luminaires in this range are designed to comply with BS EN 60598 and are suitable for operation in exterior applications. Each luminaire complies with European Directive 89/336/EEC and carries the CE mark.



# BOSTON

#### PRODUCTS AVAILABLE

Catalogue No.	Description						IP54
<b>BOS 50S</b>	50W high pressure sodium						
<b>BOS 70S</b>	70W high pressure sodium						
<b>BOS 50M</b>	50W mercury						
<b>BOS 80M</b>	80W mercury						
<b>BOS 32PL</b>	32W PL-T HF compact fluorescent						
<b>BOS 42PL</b>	42W PL-T HF compact fluorescent						
/RT	root mounting version						
/FL	flange mounting plate version						
/F	flat top option						
/D	domed top option						

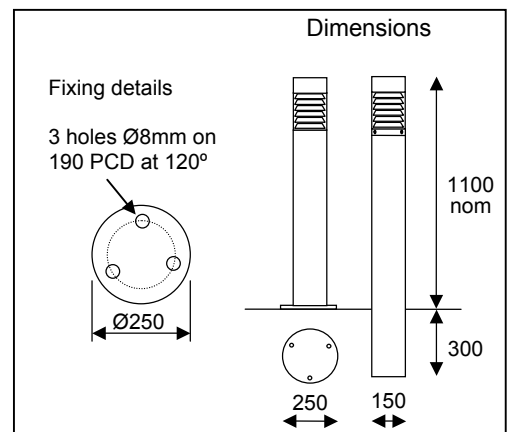

## Applications

The BOSTON range of luminaires is suitable for use in many outdoor applications. The unique design ensures that all versions are extremely resilient and are therefore suited to use in highly volatile areas where vandalism is prevalent. Such areas could be:

- Public Parking areas
- Access road lighting
- Decorative lighting in public parks
- Pedestrian precincts
- Shopping centres
- Perimeters of public buildings
- Exteriors of football grounds
- Shop anti-ram raid barriers

## Maintenance

For best results do not use abrasives or highly alkaline cleaners on the fittings. Do not use squeegees, razor blades or other sharp instruments. Do not clean the lens in hot sun or elevated temperatures.

- For removal of paints, marker pens, inks, lipstick etc., use Butyl Cellusolve on diffuser only.
- To remove labels, stickers etc., from the diffuser the use of kerosene, naphtha or white spirit is generally effective.
- After cleaning a final warm wash should be made using a mild soap solution and ending with a thorough rinse with cold water. Wipe off surface moisture from metalwork.

Generally speaking, if the luminaires operate only in the hours of darkness, a re-lamping and cleaning programme every 12 to 36 months is advisable depending on which type of lamp is used. It must be noted that High Pressure Sodium and Metal Halide lamps should be replaced before cycling occurs to prevent damage to the luminaire and control gear.

## Standards

All luminaires in the BOSTON range are designed and manufactured in accordance with the relevant sections of BS EN 60598. In addition, they comply with the requirements of European Directive 89/336/EEC and carry the CE mark. Each and every fitting undergoes stringent testing in excess of that required under the standard, to ensure that any possibility of luminaires arriving on site in anything other than full working order is kept to an absolute minimum.

## Technical Advice

Our Technical Department would be pleased to advise customers with regard to any technical aspect of Vandalite luminaires. This includes a design service using state-of-the-art computer software, or manual calculations to ensure that each project receives the correct attention for the job.

## Vandalite Lighting Ltd.

Haley Hill Works

Haley Hill

Halifax

West Yorkshire

HX3 6ED

e-mail: [enquiries@vandalite.com](mailto:enquiries@vandalite.com)

web site: [www.vandalite.com](http://www.vandalite.com)

Tel: 01422 354254

Fax: 01422 356066

All information, recommendation, or advice contained in this document or given by Vandalite Lighting Ltd., or any of its subsidiaries, affiliates, or authorised representatives, whether written or oral, is given in good faith, to the best of its knowledge, and based on current procedures in effect. The products of Vandalite Lighting Ltd. or if applicable, of its subsidiaries or affiliates are sold subject to General Conditions of Sale printed at the rear of the current catalogue or available upon request. Nothing in this or any other document shall alter, vary or supersede, or operate to waive any of the General Conditions of Sale. Each user of the products shall convince themselves, through all available sources (including finished product testing in its appropriate environment) of the suitability of the products supplied for its own particular purpose. Because actual use of the products by the user is beyond the control of Vandalite Lighting Ltd., its subsidiaries and affiliates, such use is within the exclusive responsibility of the user. Vandalite Lighting Ltd., its subsidiaries and affiliates cannot be held responsible for any loss incurred through incorrect or faulty use of the products. Information, recommendation and / or advice are neither made to infringe on any patents, nor to grant a license under any patent or intellectual property right of Vandalite Lighting Ltd. Or any of its subsidiaries or affiliated companies, nor to grant the right to file for any patent protection. We have a policy of continuous technical development and products and / or descriptions, and / or materials may be changed without prior public announcement or warning.

B  
O  
S  
T  
O  
N